

LANCOM™ Techpaper

IPv6 Tunnel Technologies

Introduction

This techpaper compares three common methods that a LANCOM router with IPv6 support can apply to provide access to the IPv6 Internet over an IPv4 connection. This may be necessary because native IPv6 Internet connections are not very widespread yet. The tunnel technologies under discussion are known as 6to4, 6in4 and 6rd. Other protocols such as Teredo are not covered by this document because they are intended for use by clients. These tunnel protocols require the local network to provide either native support of IPv6 or dual-stack support (IPv4 and IPv6).

6to4 Tunnel

In the case of a 6to4 tunnel, a dynamic tunnel is established between the local router and a 6to4 relay. The 6to4 relay is generally accessible at the anycast address 192.88.99.1. Although there are a large number of relays and the user has no control over which relay is chosen by the internet routing protocol. In addition, the relay used is determined anew for every new connection. The prefix of an IPv6 address consists of the prefix for 6to4 and the IPv4 address expressed in hexadecimal.

For example, a router with the IPv4 address 80.25.211.2 is given the prefix 2002:5019:d302::/48 (6to4 prefix 2002::/16 and IPv4 address 5019:d302). If access is to be implemented over IPv6, the client sends its request as an IPv6 packet and the router uses packet encapsulation to embed the IPv6 packet inside an IPv4 packet, which the router then transmits to the IPv6 relay. The relay then extracts the IPv6 packet for forwarding. The response is received by the relay, which is once again encapsulated within IPv4 and returned to the router, which then extracts the IPv6 package and forwards this to the client (fig. 1).

The advantages of 6to4 are numerous. First of all, the effort required for configuration is relatively low as there is no need to configure static tunnels and the 6to4 relay is selected automatically. Finally, IPv4 will be used instead of IPv6 by the client's operating system, assuming that IPv4 and IPv6 can be handled at the destination, to prevent the disruption of the communication, in case of a problem with the 6to4 relay.

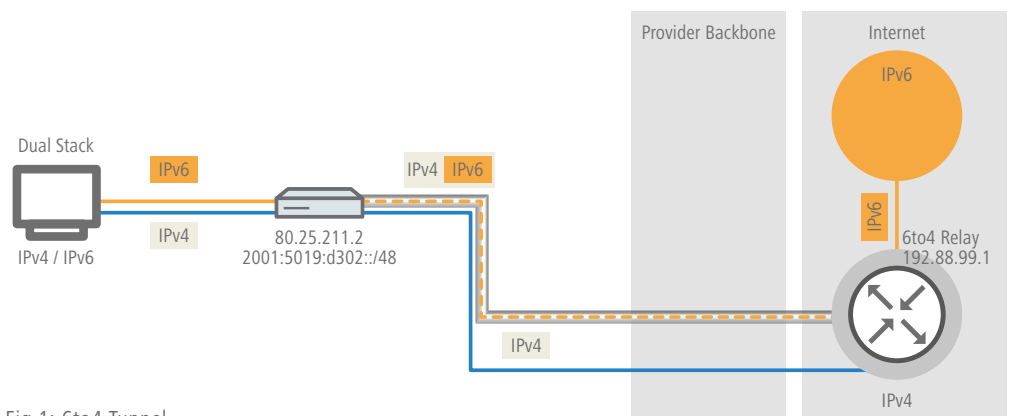

Fig.1: 6to4 Tunnel

LANCOM™ Techpaper

IPv6 Tunnel Technologies

However, there are some disadvantages associated with 6to4, chiefly associated with the dynamic selection of the 6to4 relay. The fact that it is impossible to address a specific 6to4 relay presents a security risk because neither the location nor the operator of the relay are known and the recording or manipulation of data by the provider cannot be ruled out. Another disadvantage is the stability of the connection, because there can be no guarantee that the necessary routes exist in the internet to reach all of the 6to4 relays, meaning that a connection could fail even though a tunnel has been established.

In conclusion, a 6to4 tunnel can only be considered as a viable alternative for end users. Professional application of this technique cannot be recommended due to the discussed security risks and the potential unreliability.

6in4 Tunnel

6in4 is used to interconnect two routers, two hosts, or a host and router, and makes it possible to connect two IPv6 networks over IPv4. Figure 2 shows a static 6in4 tunnel between the local router and a 6in4 relay

belonging to a tunnel broker, for example Hurricane Electric. In contrast to 6to4, the service is provided by a known entity. The end-points of the tunnel are fixed and the tunnel broker assigns a static prefix.

The advantages of a 6in4 solution including fixed 6in4 relays and also the knowledge of who the operator is. Another point is the use of a fixed prefix, for example Hurricane Electric assigns a 64 bit prefix (i.e. 2001:db8::/64) which allows the use of a full subnet. A 48 bit prefix leaves the customer 16 bit of the prefix address part for usage which allows up to 65536 subnets. The prefix is provided by the tunnel broker and a translation of the IPv4 address is not mandatory.

The disadvantage of 6in4 technology is the large amount of administrative effort involved as it is necessary to register with the selected tunnel broker. Also to be considered is the static configuration of each tunnel end point, meaning that the data must be updated regularly where the IPv4 address is assigned dynamically. However, the latter can be automated by running a script on a router.

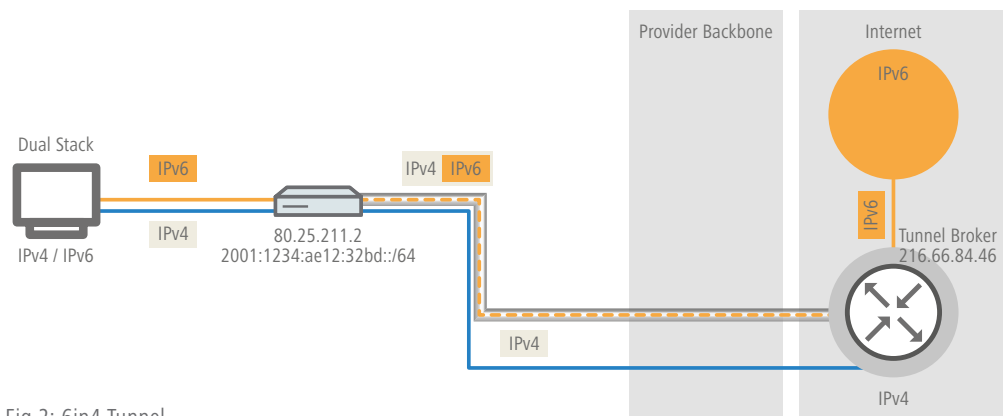

Fig.2: 6in4 Tunnel

LANCOM™ Techpaper

IPv6 Tunnel Technologies

6in4 represents a comparatively secure and stable technology for IPv6 Internet access, thus making it suitable for operating web servers that are to be accessed via IPv6. When considering that the only disadvantage is an administrative one, it is apparent that this option is suitable for professional applications.

6rd Tunnel

6rd (rapid deployment) is a further development of 6to4 and the basic mode of function is identical. The difference is that just one particular relay is used, as operated by a provider. This solves the two problems associated with 6to4, security and stability. For working with 6rd, the prefix is either configured manually or communicated via DHCP (IPv4), which further reduces the amount of configuration required at the end point. Figure 3 is a schematic representation of a 6rd scenario. The provider assigns a prefix to the router (2001:db8::/32). The router supplements this prefix with the converted IPv4 address, the result being 2001:db8:5019:d302::/64.

This makes 6rd interesting from two perspectives: First, it gives providers a simple mechanism to access the IPv6 Internet when working with an underlying IPv4 network. Second, it greatly simplifies life for the customers because they are no longer confronted by the security risks of 6to4, nor the administrative effort associated with 6in4.

Summary

6to4 cannot be recommended for professional applications owing to the security risk and lack of reliability. 6in4 and 6rd are better suited to applications in professional environments.

6rd is the most simple and secure and solution for the customers and it offers providers the option of supporting IPv6 without having to fully convert their infrastructure to IPv6.

For further information on IPv6 visit www.lancom.eu/IPv6

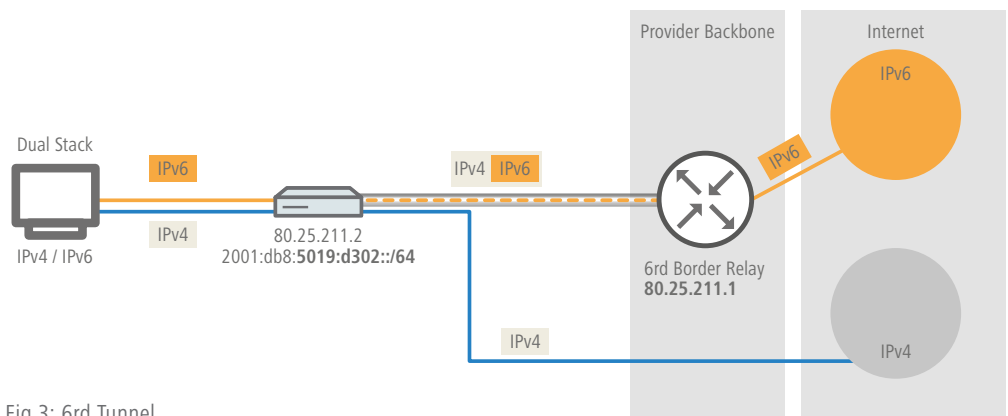

Fig.3: 6rd Tunnel